

RECESSED REGULATING GROUP WITH THERMOSTATIC MIXING VALVE

Description



Pre-assembled pump group for fixed point regulation and circulation of mixed fluid. Allows the circulation of the thermal fluid, coming from the primary circuit, by keeping the temperature at a pre-set value (fixed point) through the help of a mixing valve with thermostatic element. It is used in heating systems in general and radiant panel systems. The group is composed of a pump, thermostatic mixing valve, flow LCD thermometers, manual air vent, fittings for secondary distribution manifolds. The group can be installed with the secondary distribution manifolds on the right or the left.

The offset fitting on the flow pipe allows the installation of the group in a perfect vertical position and the coupling to manifolds with different centre distances.

Range of products

BAFA
LIST

Recessed regulating group with thermostatic mixing valve	27B	XXX	X	X	X	X
Pump threaded connections G 1 1/2		040				
Nickel-plated finish			N			
Adjustment range 20–55 °C				4		
Pump Grundfos UPM3 AUTO 25-70 130					T	
Pump Wilo Para 25-130/7-50/SC-12					P	
Pump Grundfos UPSO 25-65 130 (Extra EU)					M	
Standard version with offset fitting, Kv 3,5 and manual air vent						3

Features

Working temperature range: **5–90 °C**
 Max working pressure: **10 bar**
 Male threaded connections: **ISO 228-1**
 Primary side connection centre distance: **75 mm**
 Connection centre distance to secondary manifold (adjustable through the offset fitting): **200–211 mm**
 Pump: **Grundfos UPM3 AUTO 25-70 130**
Wilo Para 25-130/7-50/SC-12
Grundfos UPSO 25-65 130 (Extra EU)
 Suitable fluids: **water, glycol solutions (max 30%)**
 Temperature adjustment range: **20–55 °C**
 Accuracy: **±2 °C**
 Factory setting: **MIN**
 LCD thermometer scale: **20–60 °C**

Materials

Instrument holder fitting: **brass EN 12165 CW617N**
 Offset fitting: **brass EN 1982 CB753S**
 Fittings for secondary manifold:
 • Body: **brass EN 12164 CW614N**
 • Gasket: **EPDM**
 Thermometers: **liquid crystals (LCD)**

Thermostatic mixing valve

- Body: **brass EN 12165 CW617N**
- Gaskets: **EPDM**
- Headwork: **brass EN 12164 CW614N**
- Spring: **stainless steel AISI 302**
- Thermostatic sensor: **wax**
- Knob: **ABS**

Pump

- Body: **cast iron**
- Electric supply: **230 V-50/60 Hz**
- Protection class:
 Grundfos UPM3: **IP 44**
 Wilo Para: **IPx4D**
 Grundfos UPSO (Extra EU): **IP 44**
- Centre distance: **130 mm**
- Connections: **G 1 1/2 M (ISO 228-1)**
- Gaskets: **EPDM**

Components

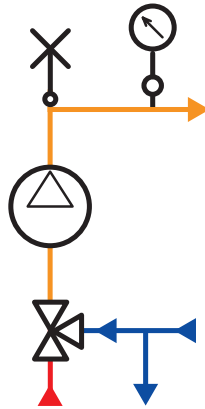
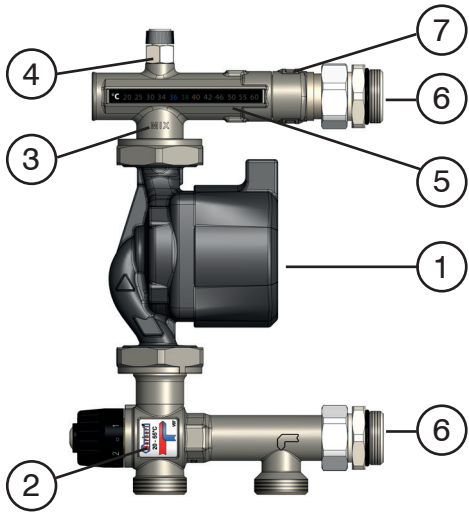

- Pump
- Thermostatic mixing valve
- Manual air vent
- LCD thermometer

27B.N		
1	Pump	Grundfos UPM3 AUTO, Wilo Para, Grundfos UPSO (Extra EU)
2	Thermostatic mixing valve	
3	Instrument holder fitting	
4	Manual air vent	
5	LCD thermometer	
6	Fittings for secondary manifold	
7	Offset fitting	

Dimensions

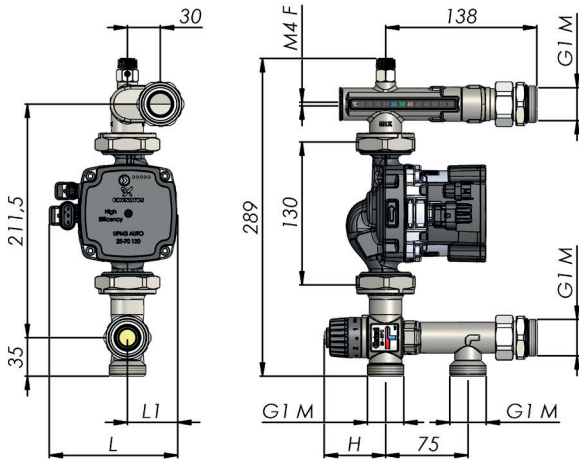

27B040N4T3

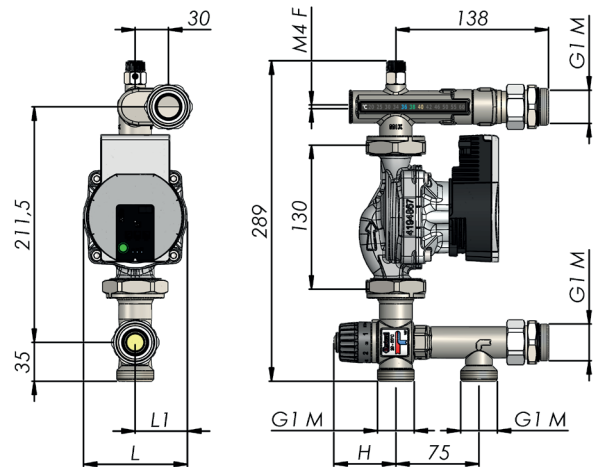

27B040N4P3

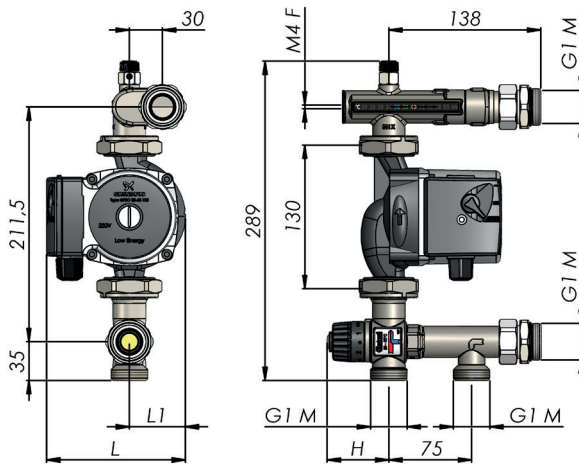

27B040N4M3

Code	P [bar]	L [mm]	L1 [mm]	H [mm]	Pump	Weight [kg]	N. P/B	N. P/C
27B 040 N4T 3	10	116	45	55,6-61,6	Grundfos UPM3 AUTO 25-70 130	3,47	-	1
27B 040 N4P 3	10	94	47	55,6-61,6	Wilo Para 25-130/7-50/SC-12	3,36	-	1
27B 040 N4M 3	10	126	51	55,6-61,6	Grundfos UPSO 25-65 130 (Extra EU)	4,07	-	1

N. P/B: number of pieces in box - N. P/C: number of pieces in carton
Other pump types should be evaluated

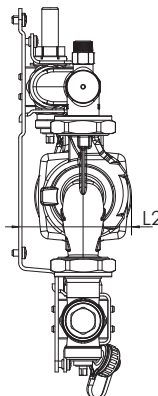

Depth of the group coupled to Barberi manifolds				
Code	L2 [mm]	Manifold	Manifold centre distance [mm]	Note
27B 040 N4T 3	131 (105*)	08M-16M	211	* with 90° rotation of the electronic part of the pump
27B 040 N4P 3	106	08M-16M	211	-
27B 040 N4M 3	135	08M-16M	211	-

Diagrams

Group sizing (operation for specialized/authorized technical personnel).

Step 1: head losses of the group without pump. Enter on the x-axis of the first diagram with the design flow rate value. Cross the curve of the group and read the corresponding head losses of the group (without pump) on the y-axis.

Step 2: available head of the pump. With the same design flow rate value, enter on the x-axis of the selected pump diagram ("Head of pump"). Cross the curve of the selected working mode (Constant speed, Proportional pressure, Constant pressure) and read the corresponding available head of the pump on the y-axis.

Step 3: pump validation. Calculate the difference between the available head of the pump and the head losses of the group without pump. The remaining pump head should be higher than the head losses of the rest of the system: if so, the selected pump is suitable to supply water to the rest of the system, otherwise a different pump working mode or pump size or different group size or a system resizing could be necessary.

Hydraulic characteristics: head losses of the thermostatic regulating group without pump

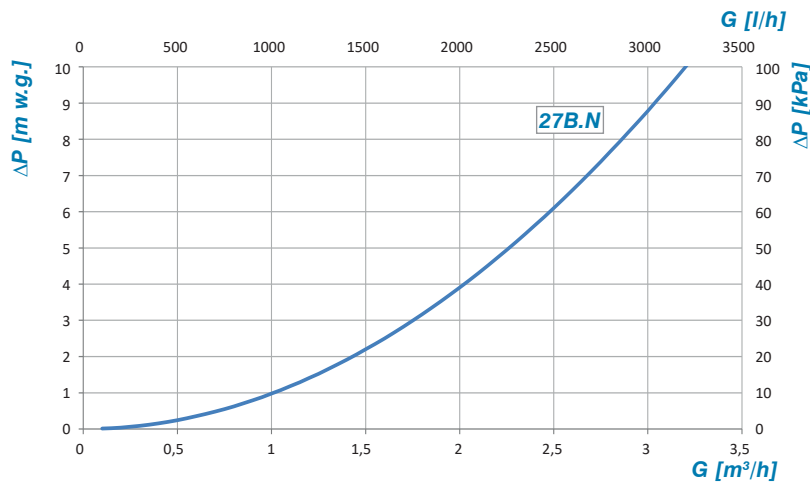

Head and power consumption of the pumps

Head of pump Wilo Para 25-130/7-50/SC-12

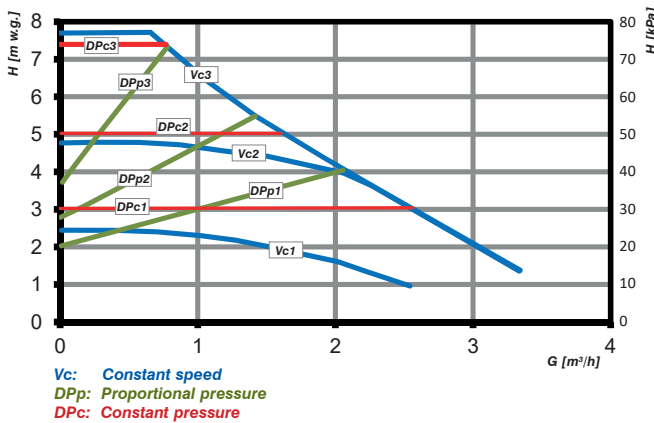

Power of pump Wilo Para 25-130/7-50/SC-12

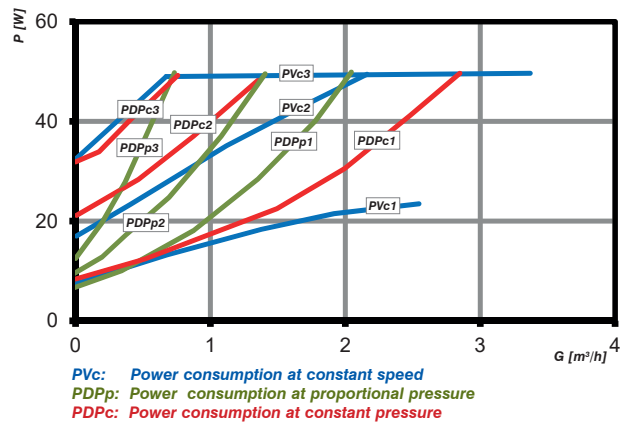

Head of pump Grundfos UPM3 AUTO 25-70 130

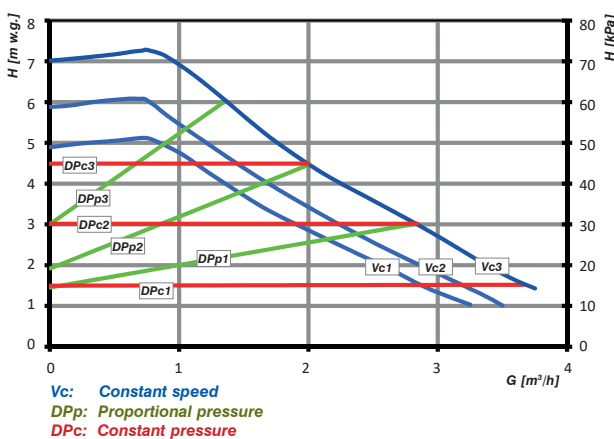

Power of pump Grundfos UPM3 AUTO 25-70 130

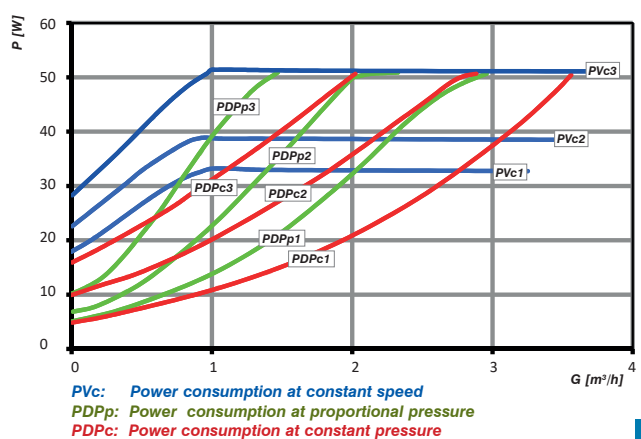

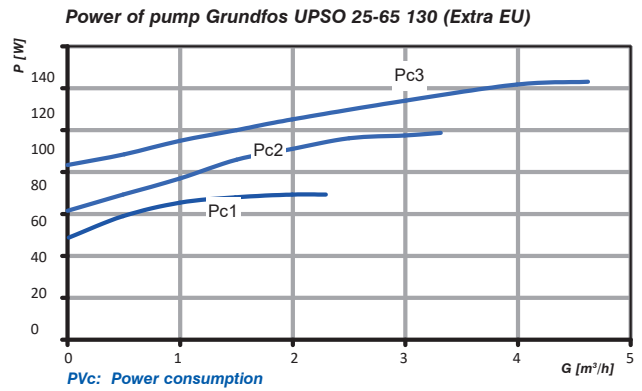
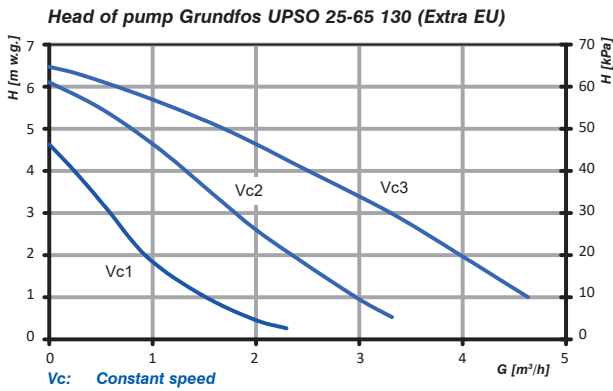

Features

The thermostatic regulating group consists of:

- Thermostatic mixing valve (2);
- Flow line including pump (1), instrument holder fitting (3), manual air vent (4), liquid cristal thermometer (5), offset fitting (6), fitting for secondary manifold (7);
- Return line including fitting for secondary manifold (7), tee built-into the valve (8).

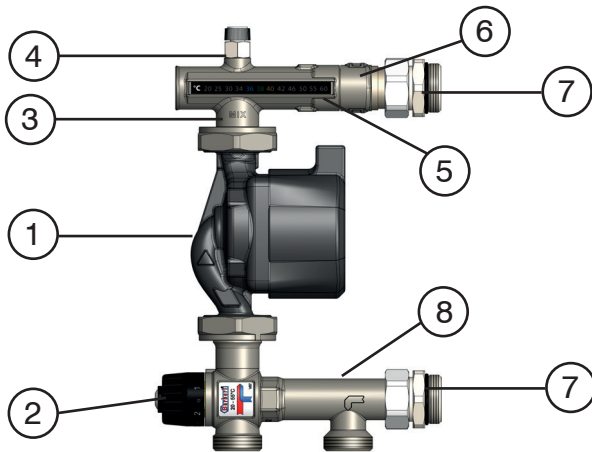

Advantages

Reversibility: thanks to the presence of a thermometer also on the rear side, the group can be easily inverted from right to left by fully reversing it (fig. A).

Flexibility of installation. The group can be installed on wall, in box or recessed (fig. B).

Monobloc structure. The thermostatic mixing valve and the instrument holder fitting, equipped with air vent and thermometers, are designed as monobloc structure. The installation is therefore immediate and points of possible leakage are reduced to a minimum.

Anti-tamper device. The device, placed within the mixing valve knob, avoids undesired variations of the setting. Slightly unscrewing the knob screw, the device is deactivated to allow the valve setting. By tightening the knob screw again, the anti-tamper is restored (fig. C).

Fast fittings. The provided fittings are equipped with O-Ring and flat gasket to make the installation faster, avoiding the use of other sealing systems like hemp or teflon tapes (fig. D).

Instrument holder fitting. Equipped with manual air vent, double LCD thermometer (on front and rear side) to check the temperature of the mixed water supplied to the system (fig. E). The offset fitting on the flow pipe allows the installation of the group in a perfect vertical position and the coupling to manifolds with different centre distances.

M4 threaded connection: fitted for the connection of an optional safety thermostat (fig. F).

Compact installation: the 75 mm centre distance of the primary side, the adjustable 200-211 mm centre distance to the secondary

manifold and the 130 mm pump make the installation very compact. **Pump range:** the groups are available with three different pump models. For the use of other models and/or manufacturers, it is advisable to contact Barberi for verification.

Flat gaskets: the various components of the groups are connected to each other by means of flat seal fittings. This makes the installation faster by avoiding the use of hemp or other sealants.

Fittings to secondary manifold: the groups are already complete with fittings to be screwed to the main connections of the secondary manifold.

The nuts are supplied loosened to facilitate the pump rotation on the installation field. Fully screw the nuts before installing the group.

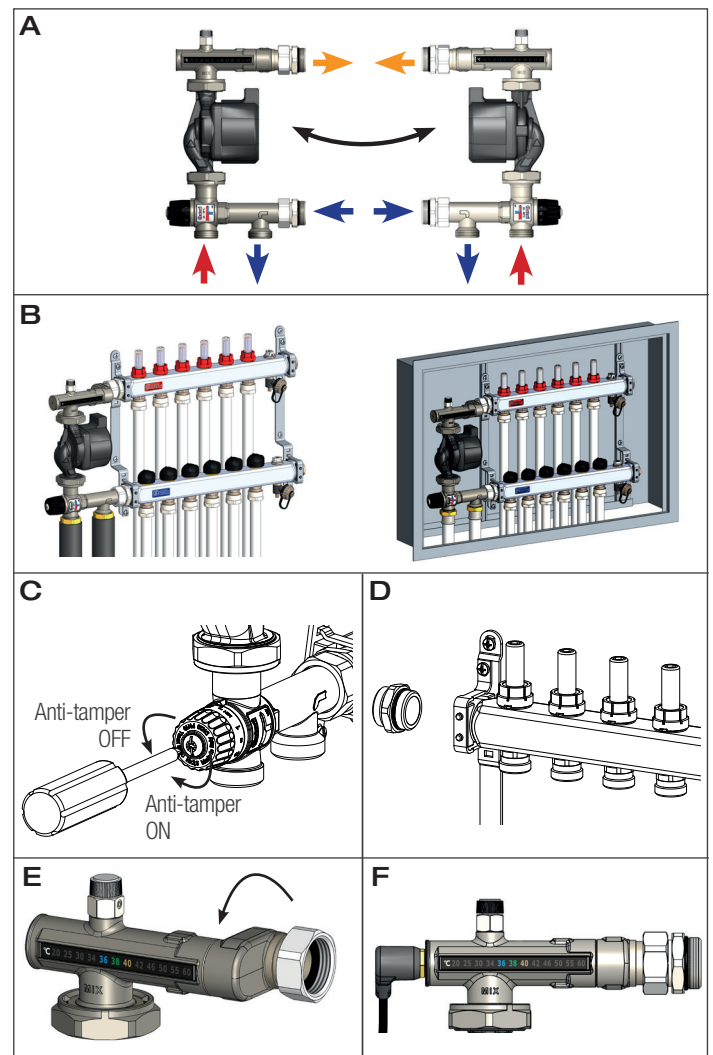

Installation

The mounting options of the group are:

- Wall installation
- Recessed installation
- Box installation

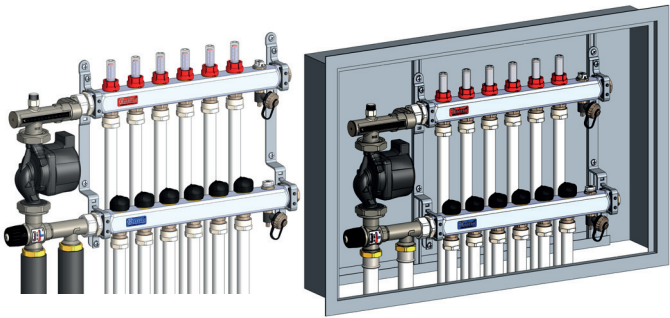

The group can be directly connected to a generator if the latter is not equipped with a pump. Instead, if the generator is equipped with a pump, an hydraulic separator should be placed between the generator and the group, in order to avoid mutual influences between the pumps. The group can be installed downstream of an inertial water storage, which performs the function of an hydraulic separator.

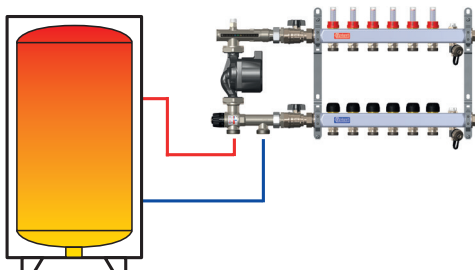
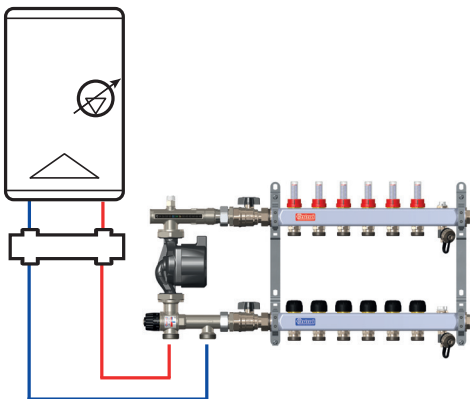
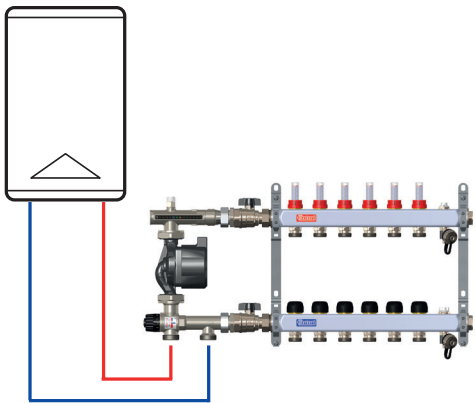

Group position

The group can be installed in one of the ways shown in the picture, with the pump rotation axis always horizontal.

12 o'clock position: suggested.

3 o'clock position: allowed only if the secondary manifold (directly connected to the group) is not equipped with flow meters or it is placed in remote position (only system flow and return pipes are directly connected to the group).

6 o'clock position: allowed but the manual air vent cannot be used anymore since it is placed upside down.

9 o'clock position: see 3 o'clock.

In any case, suitable brackets should be used to fix the group.

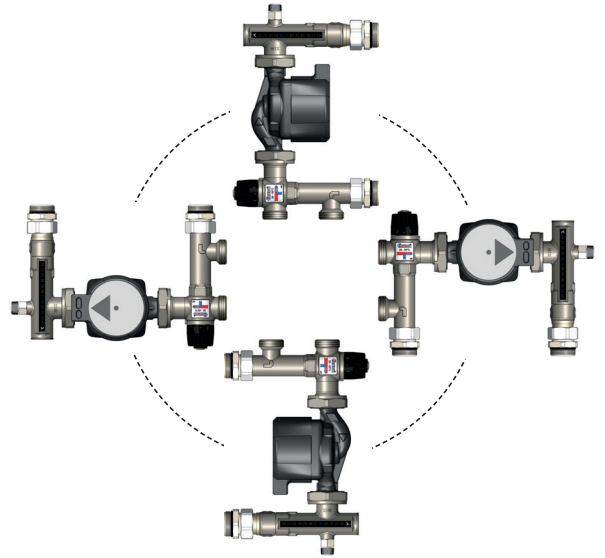

Group reversibility

The group, as shown in the picture and drawings of this datasheet, allows to directly screw a secondary distribution manifold on its right side.

Thanks to the presence of a LCD thermometer also on the rear part, the group can be fully and quickly overturned to screw a distribution manifold on its left side.

Fully screw the nuts before proceeding with the installation.

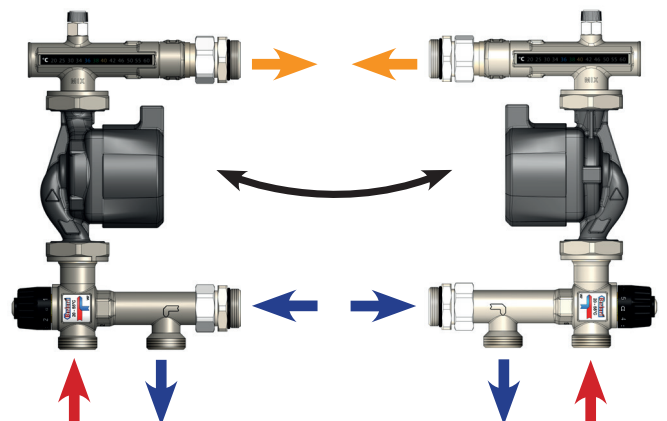

Offset fitting

The offset fitting, placed on the flow pipe, allows:

- 1) the installation of the group completely in vertical position. In this way the pipes, coming from the primary circuit, can be easily connected to the group (fig. A);
- 2) the immediate reversibility of the group. When reversing the group from right to left, it's only necessary to rotate the offset fitting by keeping the group still in a complete vertical position (Fig. B);
- 3) the possibility to connect manifolds with centre distances from 200 to 211 mm, the most common on the market (Fig. C).

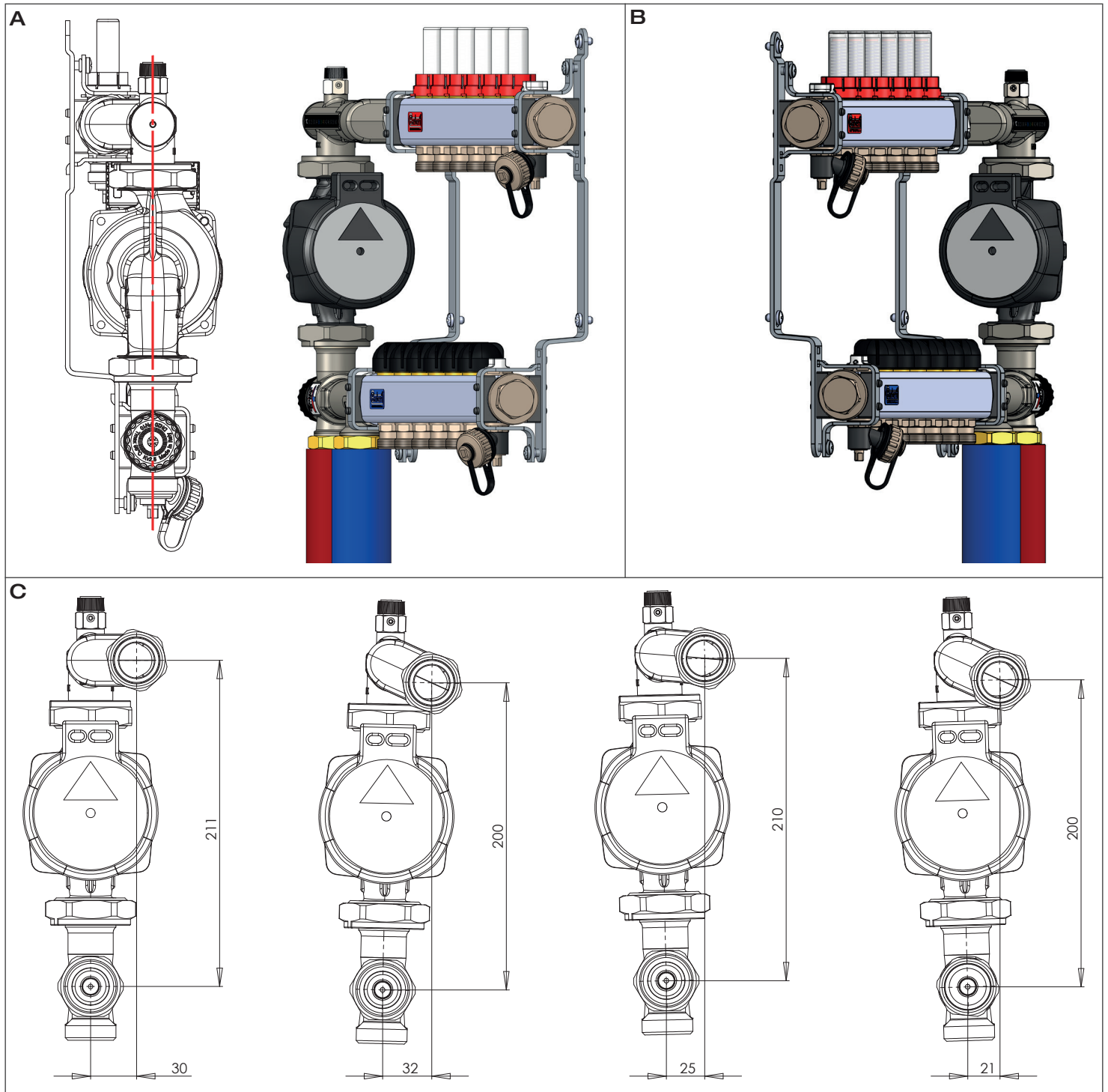
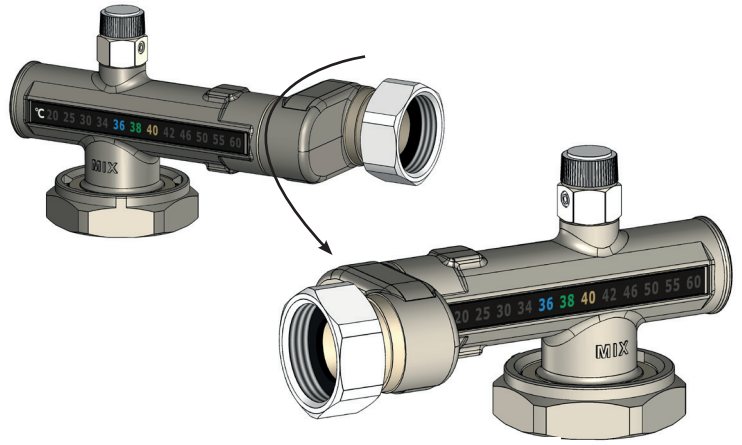

Adjustment of the thermostatic mixing valve

The thermostatic mixing valve keeps constant the temperature of the water supplied to the system. The fixed point regulation is achieved through a thermostatic sensor which moves thanks to the expansion of the wax inside of it. The sensor integrated within the valve is more precise and reliable than the thermostatic valves with external capillary.

The knob is equipped with an anti-tamper mechanism which makes the rotation difficult, thus avoiding undesired set changes. The mechanism can be released with a screwdriver, slightly loosening the locking screw.

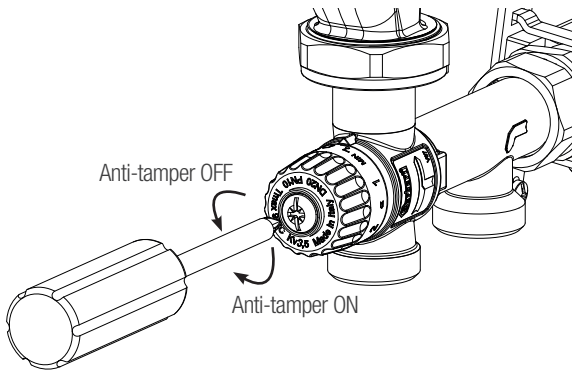
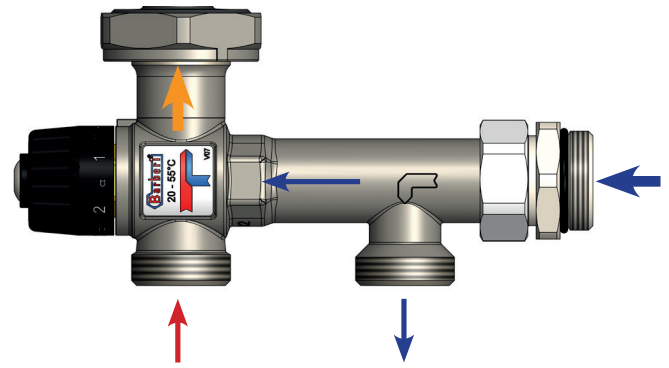

FIRST SYSTEM START UP. The fixed point temperature value can be set with the knob before installing the group or, after the installation, exclusively with the SYSTEM COLD. To set a temperature value different from the factory one, proceed as follows:

1) The graduated scale on the knob corresponds to the temperature values shown in the table.

2) With a screwdriver, slightly loosen the locking screw, holding the knob with your hand.

3) Set a mixed water temperature value slightly lower than the design temperature. Activate the generator and wait until it reaches its design working temperature (higher than the valve setting). Activate the group pump. Wait until the mixed water temperature gets stable. Read its value on the flow temperature gauge.

	20-55 °C
	°C
MIN	20
1	28
2	35
3	41
4	47
5	51
MAX	55
	MIN

4) Counterclockwise rotate step by step the knob to increase the temperature. Then wait until the temperature gets stable. Read its value on the flow temperature gauge. Proceed in the same way until the design flow temperature is reached.

5) When the desired temperature is reached, close the locking screw, holding the knob with your hand.

NEXT SETTING. If later a change should be needed in the valve setting, proceed as follows.

Case 1: temperature lower than the current setting. Let the system get cold to obtain at least a return temperature lower than the new valve setting. Follow points 1, 2, 3, 4 and 5.

Case 2: temperature higher than the current setting. In this case, the setting can be carried out also with the system running as well as with the system cold. Follow points 1, 2, 4 and 5.

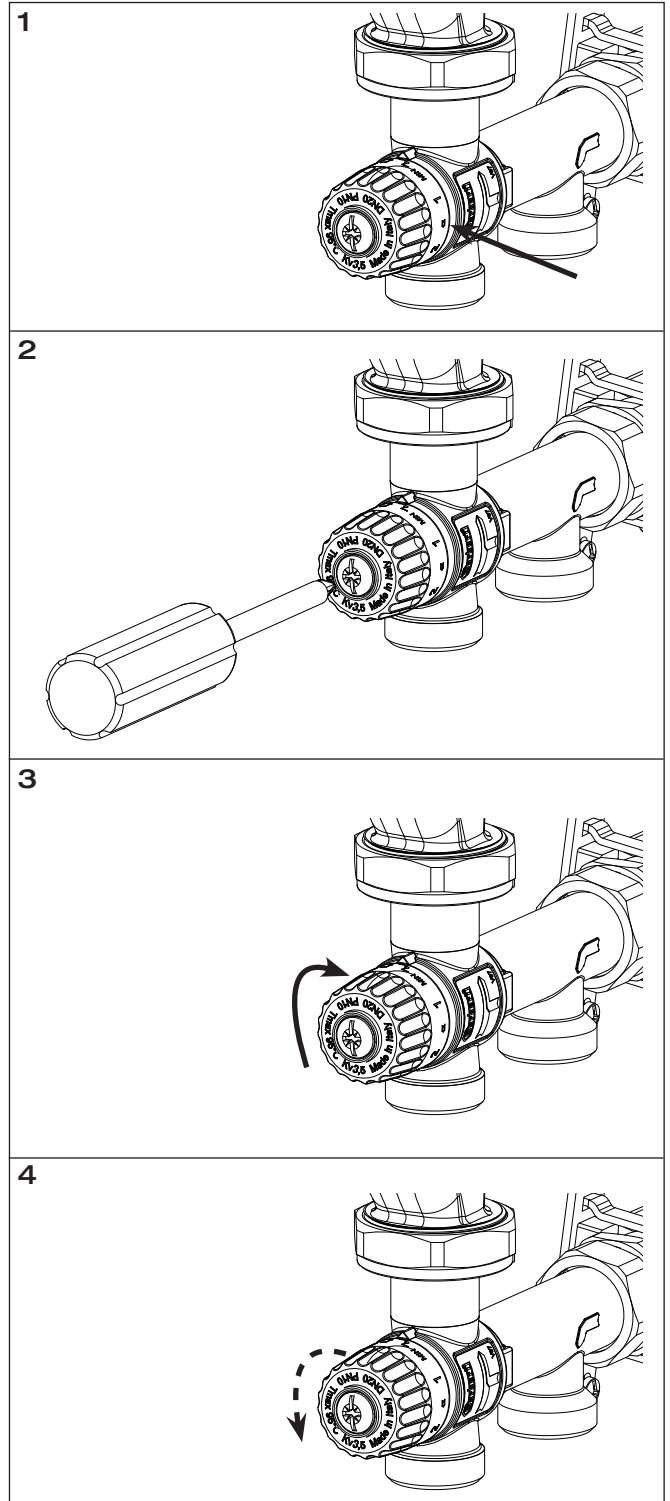

Accessories

99B

Safety thermostat kit for distribution and regulating recessed groups 27B.N-29B.N-30B.N. Normally closed with 55 °C setting, pre-wired box.

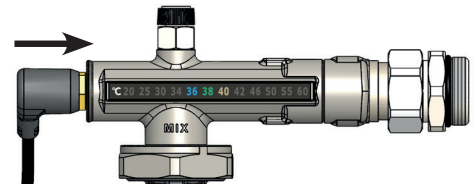
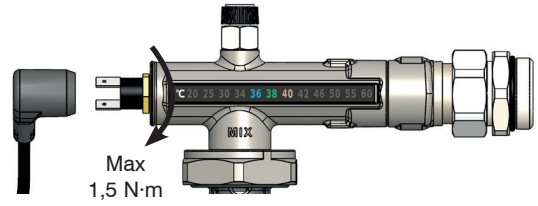

Code



99B 004 005 2

1

System diagrams

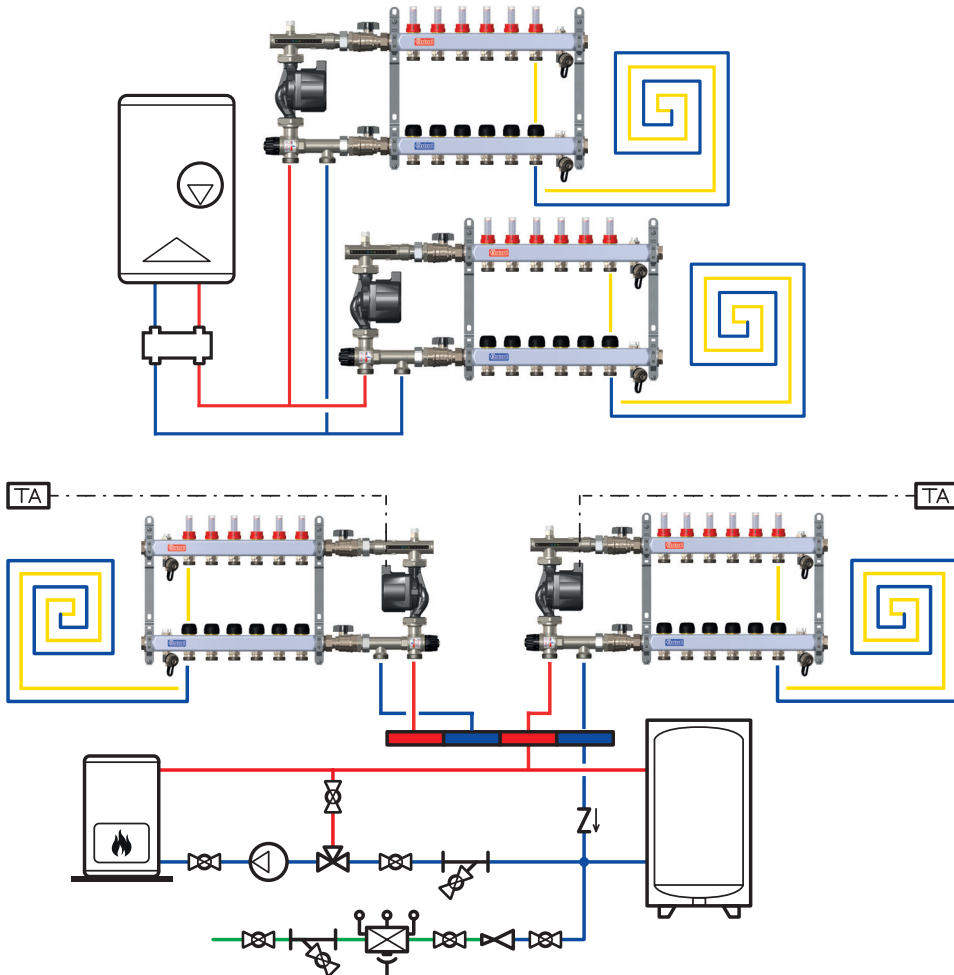

Specifications

Series 27B.N

Recessed regulating group with thermostatic mixing valve. Threaded connections G 1 M. Primary side connection centre distance 75 mm. Adjustable connection centre distance to secondary manifold 200–211 mm. The group is composed of: brass thermostatic mixing valve with wax sensor, temperature adjustment range 20–55 °C; brass instrument holder and offset fitting; liquid cristal flow thermometers with scale 20–60 °C. High-efficiency pump Grundfos UPM3 Auto 25-70 130 (Wilo Para 25-130/7-50/SC-12, 3 constant speed Grundfos UPSO 15-65 130 (Extra EU)), supply 230 V (50-60 Hz). Working temperature range 5–90 °C; maximum working pressure 10 bar.

